

Welcome to **Maeyar**



Maeyar.co.uk

Table of Contents

<i>OCCUPANCY GUIDANCE NOTES</i>	4
<i>ABOUT THE ACCOMMODATION</i>	6
Windows and Blinds	6
Night Light	6
Central Heating.....	7
Bathroom and En-Suite Extractor Fans.....	7
Shower and Hand Soap.....	7
Kitchen Equipment	7
For Children.....	8
Apartment Inventory.....	8
<i>ENJOYING YOUR TIME IN THE APARTMENT</i>	9
Television, DVD and Entertainment Systems.....	9
Broadband.....	9
Board Games, Playing Cards and Books	9
<i>SAFETY INFORMATION</i>	10
Emergency Phone Number	10
Fire Extinguisher.....	10
Gas Shut-Off Valve.....	10
Fuse box and isolator switch	10
Water Stop Cock.....	10
Smoke & Carbon Monoxide Detectors	10
<i>APPLIANCE INSTRUCTIONS/USER GUIDES</i>	11
HIVE HEATING THERMOSTAT	12
WASHING MACHINE.....	14
OVEN.....	16
COOKER HOOD	17
HOB.....	18
STAIR GATE.....	19
TRAVEL COT	20
TV REMOTE.....	21
GOOGLE SMART SPEAKER.....	22
<i>INVENTORY</i>	23
<i>WALL PICTURES</i>	25



WELCOME TO MAEYAR

This welcome folder is intended to help you get acquainted with the apartment. In it we've included information and advice from Pittenweem Properties who manage the apartment for us, as well as some additional information of our own which we hope will help to make your stay comfortable, enjoyable and memorable.

In addition to this folder you will find additional information about the apartment and the local area on our dedicated website which can be found at <https://www.maeyar.co.uk>

In furnishing and equipping Maeyar we have tried to anticipate our guests' needs by providing all the things you might want for a comfortable and enjoyable stay. It includes all the major appliances you would expect to find in your home as well as facilities for our younger guests.

While the main point of contact during your stay should be ***Pittenweem Properties*** [07758 165090] who will deal with any immediate queries or problems you may have, if you do have any comments or suggestions about the apartment, the equipment provided or the information provided in this folder which would help us make our guests even more comfortable please do let us know by email at maeyar@btinternet.com.

We hope you had a wonderful holiday, wish you a safe journey home and hope to see you again in the future.

Our very best wishes.

Jane and David

PS Don't forget to write something in the visitors book before you leave.

OCCUPANCY GUIDANCE NOTES

The following guidance is provided by Pittenweem Properties (07758 165090)



The parking space for Maeyar is located to the side of the block as indicated by the arrow (no 266). For guests with more than one car there are a number of visitor spaces between the blocks in the communal parking area marked with a 'v' on the plan.



Free Wi-Fi is provided.



The network and password details are available in this folder within the flat.

Please note that any illegal downloads or accessing of inappropriate material which leads to investigation is entirely the responsibility of the lead booking guest and no responsibility will be taken by Pittenweem Properties or property owners.



All properties are strictly non-smoking. Any guests smoking outside must do so away from the entrance/windows and dispose of cigarette ends responsibly.



Sorry, no pets are allowed at this property.



Towels are provided per guest. Towels must not be removed from the property. Please do not use towels to remove make up. Guests will be charged for linens which are soiled with makeup and require replacing.



We take pride in ensuring that all properties are presented and maintained to a high standard. We ask guest to report any damages/ breakages and inform us of any items that require replacing. Please ensure the property is left in a tidy manner. A security deposit will be taken against any deliberate damage.



Lost property will be held for a maximum of one week. Return of items will be at the guest's expense. Any items unclaimed will be donated to charity/disposed of as appropriate.



Please respect our neighbours. We politely ask all guests to enter and leave the property in a considerate manner which does not disrupt our neighbours. Please do not play loud music after 9pm.



The keybox code will be notified to you by Pittenweem Properties before you arrive. Please remember to return the key to the keybox on departure. Lost or missing keys will be subject to a charge of £30.



Guests are requested to recycle where possible and dispose of all waste in the correct bins which are located in the compound to the rear of the apartment. Bins will not be uplifted by the council if used incorrectly and a fee will be levied for removal of waste. No wipes, nappies or sanitary products should be flushed down the toilet.



CHECK OUT

Checkout is at 10 am. Changeover staff are permitted to enter the property from 10am. A late checkout fee of £30 per hour will be charged against any late checkouts which have not been preapproved.



ABOUT THE ACCOMMODATION

FIXTURES, APPLIANCES AND EQUIPMENT

Maeyar is equipped with a comprehensive range of equipment and appliances to help you to feel at home during your stay. The following pages provide you with an overview of what is available together with some brief user guides in case you need them.

Windows and Blinds

All windows are fitted with Day/Night roller blinds. Made up of two layers of fabric which glide over each other, Day/Night blinds offers versatile light control with alternating panels of sheer and opaque fabric allowing light in when open or blocking the light out when the panels are set to closed. The moveable translucent strips also allow you to control privacy levels to get as much or as little as you need. The blinds can also be rolled completely out of the way if you wish although we would ask that you leave the blinds in the opaque/day setting when you leave at the end of your stay.

The lounge balcony door venetian blinds can be operated by turning the control rods either clockwise or anti-clockwise. Please be careful not to over-turn the rods since this may damage the mechanism. If required the blinds can be pushed upwards to reveal the windows – be careful to use the central tab or better still push/pull gently using both hands to ensure the blind goes up/down evenly.

Night Light

The night light on the landing is magnetically attached and powered by a rechargeable battery. A spare pre-charged light together with the charge cable is in the small chest of drawers in the living room. While we try to ensure that the light has enough charge for your stay, should you need to swap the lights over during your stay it would be appreciated if you would recharge the swapped out light.



Central Heating

The apartment heating is controlled by a HIVE thermostat located in the lounge. Instructions on settings and how to use the controls are on page 12. We would ask that you do not attempt to alter the set programmes but feel free to manually adjust the temperatures to suit your preference and comfort by using either the boost button or by pressing and rotating the control knob as shown in the instructions.

Please do not unplug or switch off the socket below the thermostat – if you do the thermostat will not work.

Bathroom and En-Suite Extractor Fans

The extractor fans in both the bathroom and en-suite are designed to activate automatically when they sense raised humidity. When not activated they operate on a low trickle setting to help keep the apartment ventilated. Please do not switch them off.

Shower and Hand Soap

The hand and shower soap dispensers should have been replenished before you arrive. If for any reason the dispensers run low during your stay refill soap is kept in the cupboard next to the washing machine in the kitchen.

Both the bathroom and en suite also have glass cleaner and a squeegee. While the apartment will be professionally cleaned between stays, if you are able to spray the glass and squeegee the tiles after you take a shower this will help keep them clean and hygienic during your stay and for future guests.

Kitchen Equipment

Maeyar is equipped with a comprehensive range of appliances including integrated dishwasher and washer/dryer for which you will find tablets/liquid in the cupboard under the sink. Quick guides for all the main appliances can be found on pages 13 to 18. Should you need them the manufacturers' instruction manuals are located in the box file in the cupboard above the oven although we would ask that you do not attempt to change settings/installations on any of the items. If you do encounter any problems with any of the appliances please contact Pittenweem Properties in the first instance.



For Children

Provision has also been made for families with small children in particular. A high chair and travel cot including mattress (instructions for which are on page 20) can both be found stored in the main bedroom wardrobe. The travel cot will fit in the second bedroom although the beds will need to be rearranged to accommodate it. Please let Pittenweem Properties know if you intend using the cot so they can make the necessary adjustments for you.

A fitted stairgate is provided instructions for which are on page 19. There are also some beach toys which you will find in the second bedroom wardrobe, and a set of bamboo plates and cutlery in the kitchen.

Apartment Inventory

Towards the back of the folder is an inventory identifying many of the items provided to help you find your way around; we know how frustrating it can be to have to search for something when you first arrive at a property. With that in mind when you do use something if you could return it to its original location so the future guests will know where to find them that would be appreciated. Also, if there is anything you think we have missed please do let us know at maeyar@btinternet.com.



ENJOYING YOUR TIME IN THE APARTMENT

Television, DVD and Entertainment Systems

A 4K Smart TV is provided for your entertainment together with a Blu-ray player with a selection of DVDs. You are welcome to sign in to your own Amazon Prime/Netflix/YouTube etc accounts on the TV; if you do please remember to sign out before you leave. You can of course stream to the TV from your mobile devices. The TV signal is via a shared satellite dish which occasionally loses some of the digital channels although you can still access the non-digital broadcasts if that does happen.

You will also find two Google Mini smart speakers located in the lounge and main bedroom. The speakers have been set up specifically for Maeyar for basic information and entertainment (radio/podcasts etc). We would appreciate it if you did not to attempt to sync your personal google account with the speakers and we would also prefer it if you didn't move the speakers from their locations. If for any reason you are uncomfortable with smart speakers you may of course switch them off at the socket. If you are unfamiliar with Smart Speakers a basic guide can be found at page 22.

Broadband

Broadband is provided by NOW TV although please note that we do not offer the NOW TV subscription. Current download speeds tend to vary between 8 – 40 Mbps which is sufficient to view most films and operate several personal devices simultaneously.

Board Games, Playing Cards and Books

A number of games and books can be found in the small sideboard by the dining table.



SAFETY INFORMATION

Emergency Phone Number

In the event of a serious issue within the flat please call Pittenweem Properties [07758 165090]. In the case of general emergencies do not delay to call the appropriate emergency services via 999, or for non-emergency medical 111 or police 101.

Fire Extinguisher

A fire extinguisher is in the cupboard above the sink and a fire blanket is located in the kitchen on the wall by the window.

Gas Shut-Off Valve

The gas shut off valve is located to the rear of the block inside the meter box (marked plot 266 underneath where the boiler is located).

Fuse box and isolator switch

The main fuse box and isolator switch is in the cupboard by the front door.

Water Stop Cock

The water stop cock is located underneath the fuse box in the cabinet next to the front door, accessible through the access hole at the bottom of the cabinet.

Smoke & Carbon Monoxide Detectors

The flat is equipped with wired smoke and carbon monoxide detectors throughout. They are also equipped with battery back-ups. While the detectors are checked regularly, in the event that the battery low indicator (a single beep every 40 seconds) sounds please let Pittenweem Properties know immediately.



APPLIANCE INSTRUCTIONS/USER GUIDES

The following pages provide brief details of how to use the various appliances in the apartment.

If you need to refer to the complete user guide these can be found in the box file located in the kitchen in the cupboard above the oven.

We would ask that you do not change any appliance or equipment settings. If you do encounter any problems in using any of the equipment or if you believe there is a fault please advise Pittenweem Properties [07758 165090] in the first instance.

HIVE HEATING THERMOSTAT

A HIVE thermostat located in the lounge controls the heating throughout the apartment. During the summer months (April to September) the control will normally be set to manual, allowing you to vary the temperature in the flat to suit your preference. In the winter months (October to March) the control will be set to a schedule. The heating programmes have been set to ensure the temperature is kept at a comfortable level throughout the day for the duration of your stay.

While we would ask that you do not attempt to alter the set programmes you may change the temperature manually to your preferred level during any of the scheduled periods which are as follows.



Heating period
0700 to 1030
1030 to 1630
1630 to 2300
2300 to 0700

If you wish to change the temperature you can do so manually in one of two ways:

Press the control button and turn it to the desired temperature. The temperature will return to the programmed setting at the end of that period, or

Press the boost button on top of the control as shown below; repeated pressing of the boost will extend the period. The default boost temperature is 22, you can alter this by turning the control to your preferred temperature. The heating will return to the set program after the boost period.

How to boost your heating for a short time:

- 1 Press the **Heating Boost**  button on top of the thermostat to turn the heating on
- 2 Press the **Heating Boost**  button again to increase the length of your boost
- 3 Turn the dial to change the boost temperature (it's set to 22°C by default)
- 4 When the boost finishes, your heating will go back to its previous mode
- 5 To cancel boost early, press the **Back**  button.

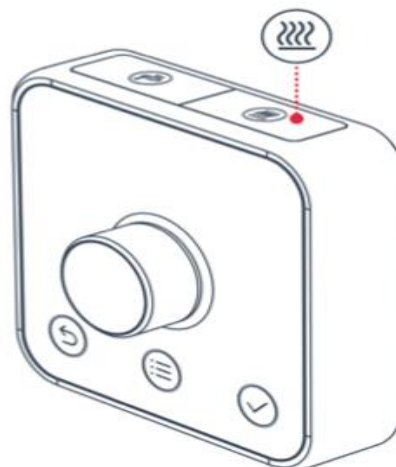

DISHWASHER

SETTING AND STARTING A PROGRAMME Starting a programme

1. Load the baskets
2. Add the detergent tablet
3. Keep the appliance door ajar
4. Press the on/off button to activate.
5. Make sure that the appliance is in programme selection mode.
6. Press the programme button repeatedly until the indicator of the programme you want to select starts flashing.
7. Close the appliance door to start the programme.

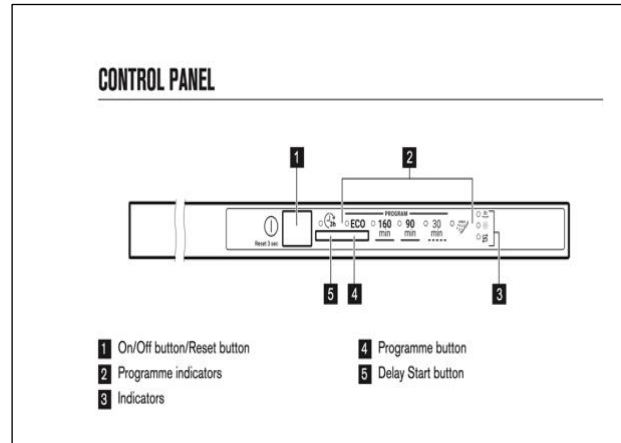

Cancelling the programme

Press and hold the programme button for 3 seconds until the appliance is in programme selection mode.

Make sure that there is detergent in the detergent dispenser before you start a new programme.

Opening the door while the appliance operates

Opening the door while a programme is running stops the appliance. It may affect the energy consumption and the programme duration. After closing the door, the appliance continues from the point of interruption. If the door is opened for more than 30 seconds during the drying phase, the running programme ends.

The Auto Off function

This function decreases energy consumption by deactivating the appliance automatically when it is not operating. The function comes into operation either when the programme is complete or after 5 minutes if a programme is not started.

End of the programme

When the programme is complete the door will open slightly and the programme indicator remains on until the Auto Off function switches the appliance off.

Press any button to switch off the appliance or wait for the appliance to switch off automatically. If you close or open the door before automatic deactivation, the appliance is deactivated.

WASHING MACHINE

WASHING

1. Turn the programme dial to select the desired washing programme.
The indicator of Mode - Wash button illuminates.
The indicator of the Start/Pause button flashes and the display shows the programme duration.
2. Press the lever down to remove the dispenser.
3. To use powder detergent, turn the flap up.
4. To use liquid detergent, turn the flap down.
5. Measure out the detergent and the fabric conditioner.
6. Carefully close the detergent dispenser.

DRYING

1. Press the On/Off button for some seconds to activate the appliance.
2. Load the laundry one item at a time.
3. Turn the programme dial to the programme suitable for the items to dry. The appliance defaults to the washing only mode and the indicator of the Mode - Wash button is on.
4. Tap on the Mode button twice to perform drying only. The indicator of Mode - Dry button illuminates and the indicator of Mode - Wash button goes off.

WASHING AND DRYING

1. Press the On/Off button for some seconds to activate the appliance.
2. Load the laundry one item at a time.
3. Put the detergent and the additives in the appropriate compartment.
4. Turn the programme dial to the washing programme. The appliance defaults to the washing only mode and the indicator of the Mode - Wash button is on. The display shows the default temperature and spin. If necessary, change them according to your laundry.
5. Set the desired options, if there are available.
6. Tap on the Mode button once to activate also the drying function. Both indicators of the Mode - Wash and Mode - Dry buttons are on.

DRYING - AUTOMATIC LEVELS

1. Tap on the Auto Dry button repeatedly until the display shows the required dryness level.
The indicators in the display illuminate accordingly
2. Touch the Start/Pause programme.
3. In the display the door locked indicator comes on. The display also shows the remaining programme time.

STARTING A PROGRAMME

1. Touch the Start/Pause button to start the programme. It is not possible to start the programme when the indicator of the button is off and doesn't flash (e.g. the door is open).
2. The related indicator stops flashing and stays on. The programme starts, the door is locked. The display shows the door locked indicator.
[The drain pump can operate shortly before the appliance fills water].

CONTROL PANEL

CONTROL PANEL DESCRIPTION

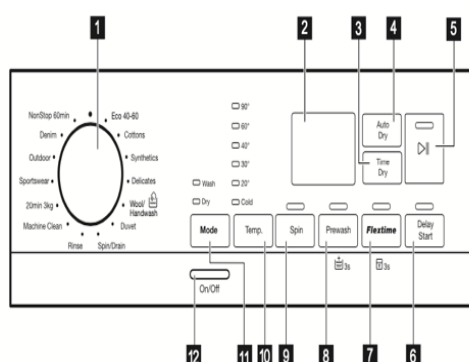

i The permanent options are set by holding pressed the relative button for at least 3 seconds.

- 1 Programme dial
- 2 Display
- 3 Time Dry touch button
- 4 Auto Dry touch button
- 5 Start/Pause touch button
- 6 Delay Start touch button
- 7 Flextime touch button and permanent Child Lock option

- 8 Prewash touch button and permanent Extra Rinse option
- 9 Spin touch button
- 10 Temp. touch button
- 11 Mode touch button:
 - Mode - Wash
 - Mode - Dry
- 12 On/Off push button

DISPLAY

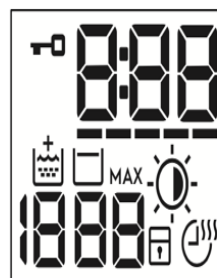

	Door locked indicator.
	The digital indicator can show: <ul style="list-style-type: none"> • Programme duration (e. g. 2:40, washing and/or drying phase). • Delay time (e. g. 2h). • Cycle end (0:00). • Warning code (e.g. E20). • Error indicator (- - -).
	Flextime indicator.
	Extra Rinse indicator.
	The spin area: Spin speed indicator - - - No Spin indicator. Spin phase is off.
	Rinse Hold indicator.
MAX	After the AutoAdjust System detection, it flashes when the laundry load exceeds the maximum declared load of the selected programme. Refer to "The AutoAdjust System load detection" paragraph.
	Auto Dry indicator: ☀ Iron dry ☀ Cupboard dry ☀ Extra dry
	Child safety lock indicator.
	Time Dry and Non-Stop programme indicator.

OVEN

HEATING FUNCTIONS

Oven function	Application
Off position	The oven is off.
Light	To turn on the lamp.
True Fan Cooking	To bake on up to two shelf positions at the same time and to dry food.
Moist Fan Baking	This function is designed to save energy during cooking. When you use this function, the temperature in the cavity may differ from the set temperature. The heating power may be reduced. For more information refer to "Daily Use" chapter, Notes on: Moist Fan Baking.
Defrost	To defrost food (vegetables and fruit). The defrosting time depends on the amount and size of the frozen food.

Oven function	Application
Grill	To grill thin pieces of food and to toast bread.

NOTES ON: MOIST FAN BAKING

This function was used to comply with the energy efficiency class and ecodesign requirements according to EU 65/2014 and EU 66/2014. Tests according to EN 60350-1. The oven door should be closed during cooking so that the function is not interrupted and the oven operates with the highest energy efficiency possible.

For the cooking instructions refer to "Hints and tips" chapter, Moist Fan Baking. For general energy saving recommendations refer to "Energy Efficiency" chapter, Energy Saving.

SETTING A HEATING FUNCTION

1. Turn the knob for the heating functions to select a heating function.
2. Turn the control knob to select the temperature.
3. The lamp turns on when the oven operates.
3. To turn off the oven, turn the knob for the heating functions to the off position.

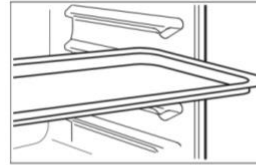

TRIVET AND GRILL- / ROASTING PAN

WARNING! Be careful when you remove the accessories from a hot oven. There is a risk of burns.

You can use the trivet to roast larger pieces of meat or poultry on one shelf position.

1. Put the trivet into the deep pan so that the supports of the wire shelf point up.

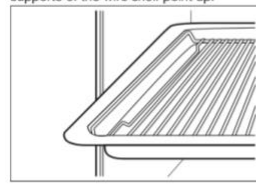

2. Put the deep pan into the oven on the necessary shelf position. You can use the trivet to grill flat dishes in large quantities and to toast.

1. Put the trivet into the deep pan so that the supports of the wire shelf point down.

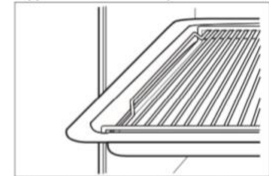

2. Put the deep pan into the oven on the necessary shelf position.

USING THE ACCESSORIES

WARNING! Refer to Safety chapters.

INSERTING THE ACCESSORIES

Wire shelf:
Push the shelf between the guide bars of the shelf support and make sure that the feet point down.

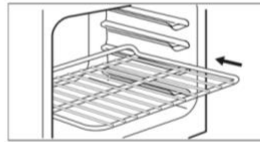

Deep pan:
Push the deep pan between the guide bars of the shelf support.

ADDITIONAL FUNCTIONS

COOLING FAN

When the oven operates, the cooling fan turns on automatically to keep the surfaces of the oven cool. If you turn off the oven, the cooling fan stops.

prevent this, the oven has a safety thermostat which interrupts the power supply. The oven turns on again automatically when the temperature drops.

SAFETY THERMOSTAT

Incorrect operation of the oven or defective components can cause dangerous overheating. To

HINTS AND TIPS

WARNING! Refer to Safety chapters.

COOKING RECOMMENDATIONS

The oven has four shelf positions. Count the shelf positions from the bottom of the oven floor. Your oven may bake or roast differently to the oven you had before. The below tables provide you with

The temperature and cooking times in the tables are guidelines only. They depend on the recipes and the quality and quantity of the ingredients used.

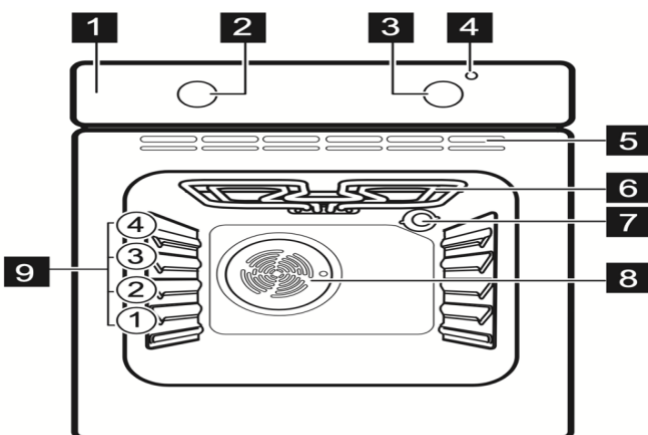

- 1 Control panel
- 2 Knob for the heating functions
- 3 Control knob (for the temperature)
- 4 Temperature indicator / symbol
- 5 Air vents for the cooling fan
- 6 Heating element
- 7 Lamp
- 8 Fan
- 9 Shelf positions

COOKER HOOD

CONTROLS

The hood is fitted with a control panel with aspiration speed selection control and a light switch to control cooking area lights.

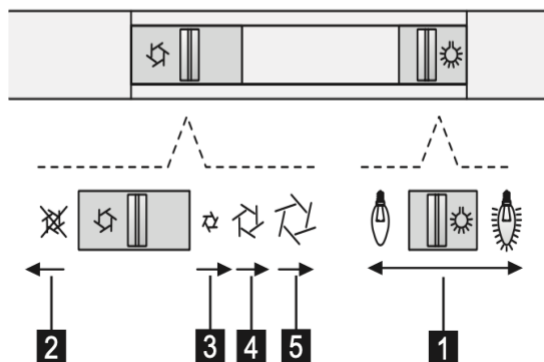

- 1** ON/OFF lights
- 2** OFF motors
- 3** Minimum suction power
- 4** Medium suction power
- 5** Maximum suction power

Use the high suction speed in cases of concentrated kitchen vapours. It is recommended that the cooker hood suction is switched on for 5 minutes prior to cooking and to leave in operation during cooking and for another 15 minutes approximately after terminating cooking.

LIGHTING

Disconnect the hood from the electricity.

Warning! Prior to touching the light bulbs ensure they are cooled down.

Replace the damaged lamp.

Use E14 2,5W max LED lamps only. For more details, check enclosed leaflet "ILCOS D" (alphanumeric position "1e").

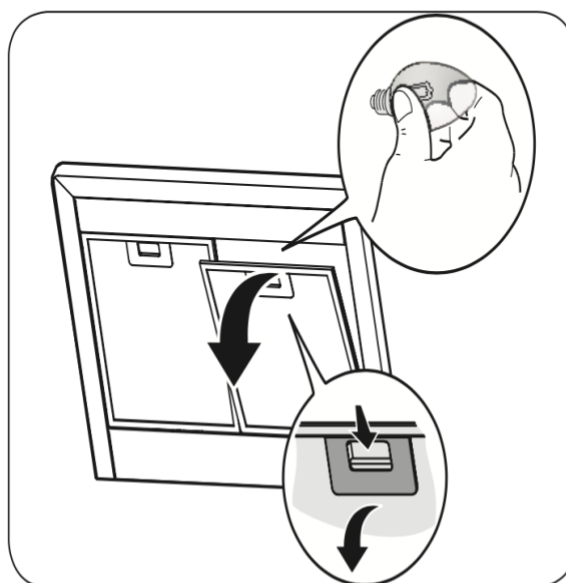

HOB

DAILY USE



WARNING! Refer to Safety chapters.

BURNER OVERVIEW

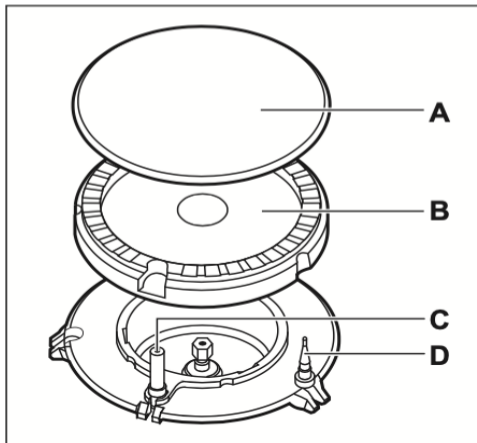

- A. Burner cap
- B. Burner crown
- C. Ignition candle
- D. Thermocouple

IGNITION OF THE BURNER



Always light the burner before you put on the cookware.



WARNING! Be very careful when you use open fire in the kitchen environment. The manufacturer declines any responsibility in case of the flame misuse.

1. Push the control knob down and turn it counterclockwise to the maximum gas supply position (Ⓐ).

2. Keep the control knob pushed for equal or less than 10 seconds. This lets the thermocouple warm up. If not, the gas supply is interrupted.
3. Adjust the flame after it is regular.



If after some tries the burner does not light, check if the crown and its cap are in correct positions.



WARNING! Do not keep the control knob pushed for more than 15 seconds. If the burner does not light after 15 seconds, release the control knob, turn it into off position and try to light the burner again after minimum 1 minute.



CAUTION! In the absence of electricity you can ignite the burner without electrical device; in this case approach the burner with a flame, turn the control knob counter-clockwise to maximum gas supply position and push it down. Keep the control knob pushed for equal or less than 10 seconds to let the thermocouple warm up.



If the burner accidentally goes out, turn the control knob to the off position and try to light the burner again after minimum 1 minute.



The spark generator can start automatically when you switch on the mains, after installation or a power cut. It is normal.



The hob is supplied with the progressive valves. They make the flame regulation more precise.

STAIR GATE

HOW TO OPERATE

8

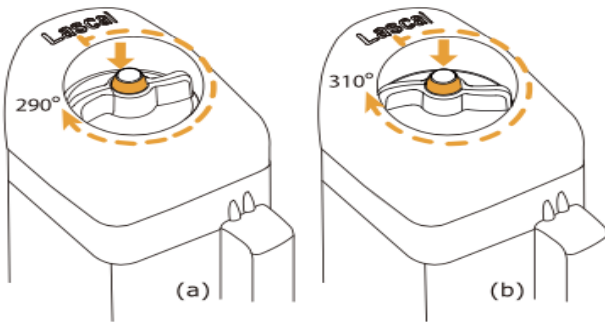

8. Locking System

Locking/Unlocking options:

- Timed lock** - Push and turn the locking button clockwise up to 290°. You will have a few seconds to draw the gate open and closed before it locks. **TIP:** The more you turn the button up to 290°, the more time you will have to close or open the gate.
- Manual lock** - Push and turn the locking button clockwise through to 310°. The gate will be permanently free to open or close, with no time limitation. The gate will not lock until you turn the locking button anti-clockwise, back beyond the 290° position for timed locking or back to 0° for immediate locking.

NOTE

The Lock Indicator shows red when the gate is unlocked and does not provide a protective barrier.

The KiddyGuard® Avant is easy to operate single-handed.

9

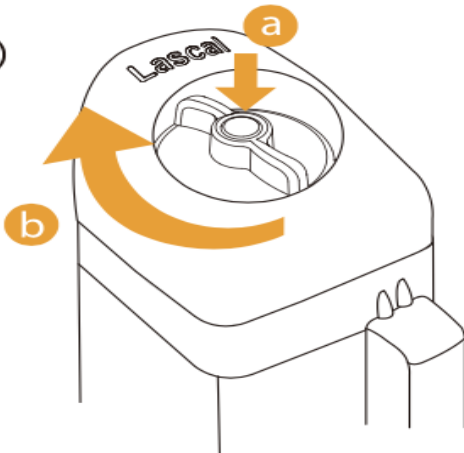

EN

9. To close the KiddyGuard® Avant

- Push down the button on the top of the gate.
- Turn the button clockwise. see Fig 8.
- Use the Handle to pull the gate across and hook it onto the Locking Strip. see Fig 10.

IMPORTANT

AFTER CLOSING THE KIDDYGUARD® AVANT, ALWAYS CHECK THAT THE GATE IS LOCKED BY PUSHING GENTLY AGAINST THE MESH.

10

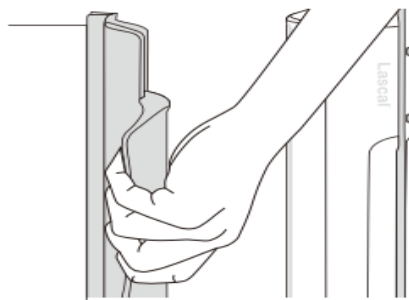

10. To open the KiddyGuard® Avant

Release the gate by repeating the operations 9a and 9b. Unhook the gate and let it roll up.

IMPORTANT

CONTINUE TO HOLD THE HANDLE WHILE THE GATE ROLLS UP.

TRAVEL COT

IMPORTANT, RETAIN FOR FUTURE REFERENCE: READ CAREFULLY
Travel Cot Assembly

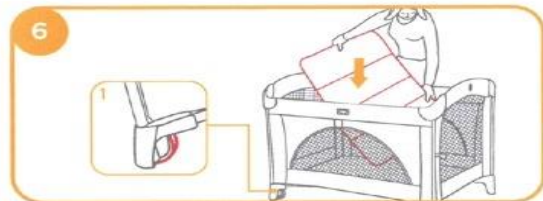
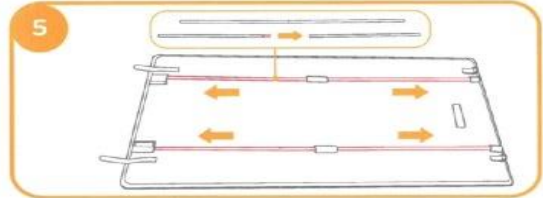
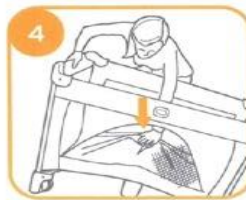
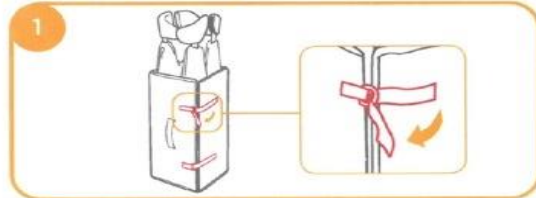

Fold Travel Cot

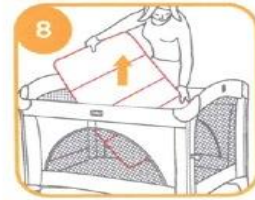

1

2

FIGURE 9 - 13

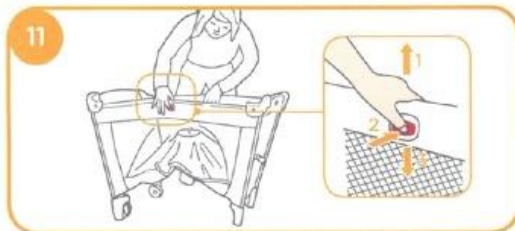
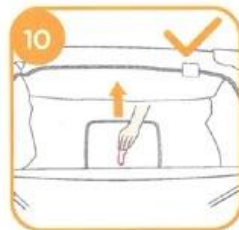

Cover Travel Cot



CO-SLEEPING MODE (FIXING TO THE BED)

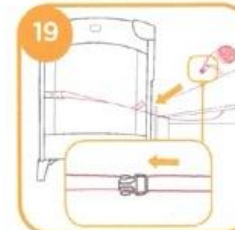

3

4

FIGURE 14 - 19

TV REMOTE

About the Buttons on the Samsung Smart Remote

- The images, buttons, and functions of the Samsung Smart Remote may differ depending on the model.
- The Universal Remote function operates normally only when you use the Samsung Smart Remote that comes with the TV.

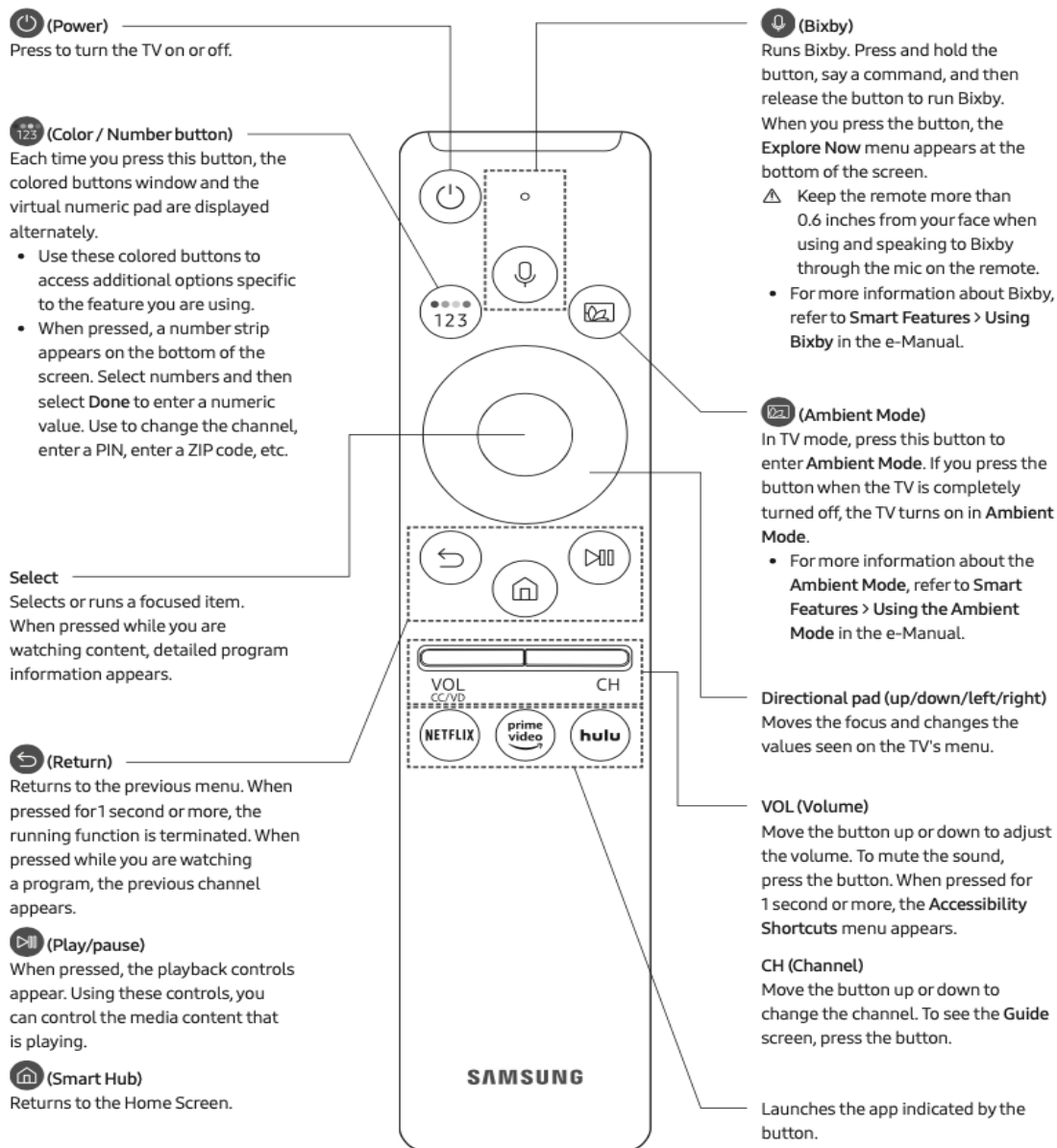

English - 10

GOOGLE SMART SPEAKER

Google Mini smart speakers will activate when they hear the command "Hey Google" or "OK Google". While you can alter the volume with the command "lower/raise volume" or "volume 2/3/4 etc the units also include hidden touch controls as shown in the diagram.

Examples of Google Assistant commands

Here are five of the most important Home commands to get started with, which you can choose to start with either **"Hey Google"** or **"OK Google"**. For example:

"Hey Google, stop."

"Hey Google, play [song title] by [artist] from Spotify."

"Hey Google, turn [up/down] the sound."

"Hey Google, what's the time?"



Controlling music, podcasts, radio and audiobooks

- "Hey Google, play some Oasis."
- "Hey Google, play Classic FM."
- "Hey Google, stop the music in 15 minutes."
- "Hey Google, play some ambient noise"
- "Hey Google, pause the music."
- "Hey Google, stop the music."

Setting timers and alarms

- "Hey Google, set a timer for 10 minutes."
- "Hey Google, set an alarm for 7.30 tomorrow morning."
- "Hey Google, cancel the alarm for 8.30."
- "Hey Google, good night (will prompt a request for an alarm time and then play some sleep sound).

General queries and commands

- "Hey Google, what's the weather like today?"
- "Hey Google, is it windy this morning?"
- "Hey Google, what's today's headlines?"
- "Hey Google, how do you make mushroom risotto?"
- "Hey Google, spell manoeuvre."

INVENTORY

The following lists are not an exhaustive inventory but provide an indication of the items and equipment provided and an idea of where to find them.

If anything is missing either off the list or you think that we could usefully provide additional items for guest please drop us a line at maeyar@btinternet.com

Main Bedroom
hair straighteners rest mat
hairdryer (in pink bag)
travel cot mattress (bedding)
travel cot
high chair

Second Bedroom
hoover (Hetty)
picnic blankets
beach toys
clothes drying rack
ironing board

Kitchen	
small step	cupboard under the boiler
window squeegee	
mop	
bucket	
Iron	cupboard above the sink
first aid kit	
fire extinguisher	
small toolkit	
spare batteries and bulbs	

Cooking utensils	
salad forks	mixing bowl x 2 1L/23cm
solid spoon	kitchen scales
masher	measuring jug
slotted spoon	chopping boards set of 2
fish slice	baking tray/roasting dish x2
spatula	pizza tray x 2
corkscrew	set of sharp knives -3 pc
tin opener	bread knife
scissors	kitchen paper holder
grater	potato peeler
colander	pizza wheel
cafetiere	pizza board
jug for drinks	ice cube tray
trivet x 2	dish brush
ramekins	storage boxes
casserole dish	carving fork
set of pans	butter dish
oven gloves (2 sets)	tea leaf strainer
tongs	rolling pin
whisk	sieve
range of serving utensils	bread bin

Other items	Location
Torch and night light	Lounge
Google mini x 3	Lounge and both bedrooms
Samsung TV	Lounge
DVD player + assorted DVDs	Lounge
Binoculars	Lounge
Assorted games	Lounge

WALL PICTURES

The pictures on the walls of the apartment are of local views all taken from within walking distance of the apartment illustrating something of the beauty of the local area. We have included short descriptions of the views in case you are wondering where they were taken from:

Entrance

Towards the Isle of May taken from the harbour wall in [Cellardyke](#)



The RNLI station on Shore Street in [Anstruther](#)



Landing

Looking back at [St Monans](#) from the harbour wall



Dining Area

Opposite views towards the East and West from the Fife Coastal Path close to the first tee/9th Green of [Anstruther Golf Course](#)



Lounge Area

View towards the Isle of May from
East Shore in St Monans



A Saltire on the Fife Coastal path between
Anstruther and Pittenweem



Main Bedroom

Looking West from the Coastal Path
near Pittenweem



Taken from Cellardyke Harbour looking west

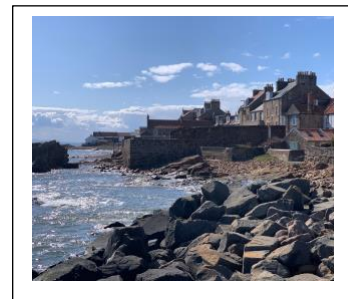

Second Bedroom

Located to the east of the village of Elie with a backdrop of dunes and overlooking the Firth of Forth, Ruby Bay is a sheltered sandy beach which forms part of the Fife Coastal Path and with access to beautiful walks in the surrounding countryside.



The Lady's Tower at Elie incorporated a vaulted chamber at sea level as a changing room, was built in the 1770s for Janet, Lady Anstruther. Allegedly Lady Anstruther would instruct a servant to ring the bell in the town while she bathed to ensure locals stayed away.



Bathroom

Towards the Isle of May from the Coastal Path to the east of Cellardyke

